

SILICON VALLEY'S AIRPORT



Airport Capital Projects Update

August 8, 2016 Airport Commission

Airport Capital Projects



- Prudent Financial Decisions
- Available Unspent Bond Proceeds from Terminal Area Improvement Program
- Essential Capital Projects
 - Focus on Benefits that:
 - Improve Airfield Safety and Security
 - Enhance Customer Service
 - Provide Pedestrian Ground Level Roadway Crossings
 - Modernization and Enhance Ground Transportation
 - Facilities Consistent with Terminal B

Airport Capital Projects



Unspent Bond Proceeds Projects

Airport Perimeter Fence = \$5.2 M

FIS Projects = \$8.1M

2 ARFF Vehicles = \$2.1M (*partially FAA funded*)

RIM Airfield Study = \$1.9M

Security Technology = \$14 M (*partially FAA funded*)

Terminal A Roadway Safety Improvements = \$3.5M

Southeast Ramp Reconstruction = \$8.9 M

Gate 29 and Gate 30 Improvements = \$10 M

Airport Monument Sign = \$750,000

Miscellaneous Projects

Relocate Northeast Electrical Supply

Terminal Upgrades

Southeast Building Demolition

Police Department Relocation

Central Plant Upgrades

Airfield Fencing



Estimate: \$5.2 million
Completion: August 2016



Federal Inspection Services



Estimate: \$8.1 million
Completion: March 2017



Federal Inspection Services



Federal Inspection Services



Federal Inspection Services

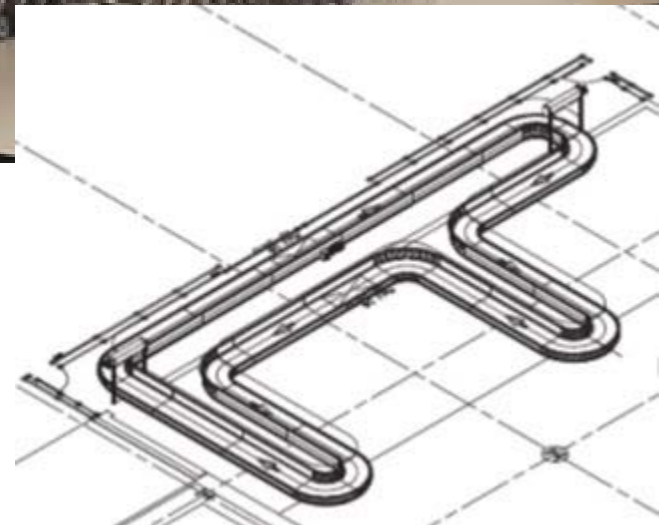
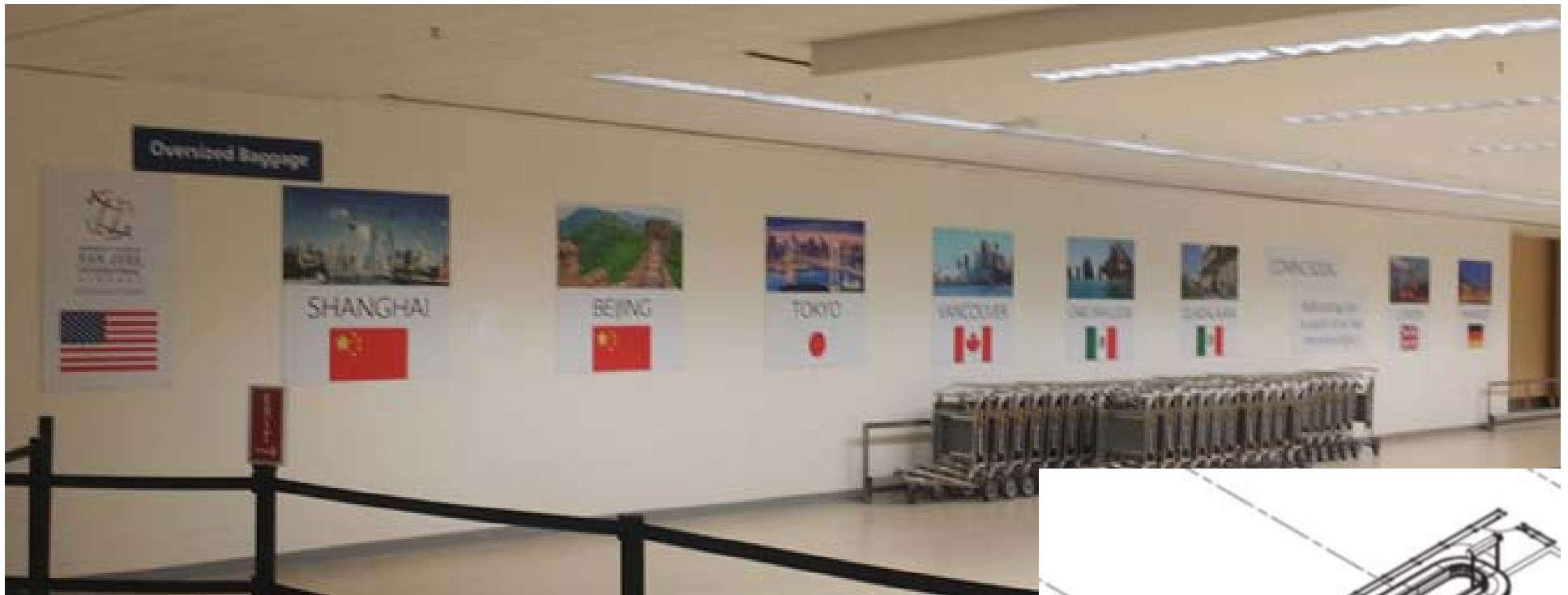

ARFF Trucks



At the

Estimate: \$2.1 million
Completion: Summer 2017



Runway Incursion Mitigation Design Standards Analysis



Project Scope

- Analyze operational and design changes
- Develop strategies to enhance safety
- Prepare Aeronautical Study



Benefits

- Improve Safety
- Mitigate Risk of Unintended Runway Incursions
- Collaborative Process



Funding

- \$1,500,000 FAA AIP Grant
- \$1,900,000 Total Project Cost
- Completion June 2018

Runway Incursion Mitigation Design Standards Analysis



Current Conditions

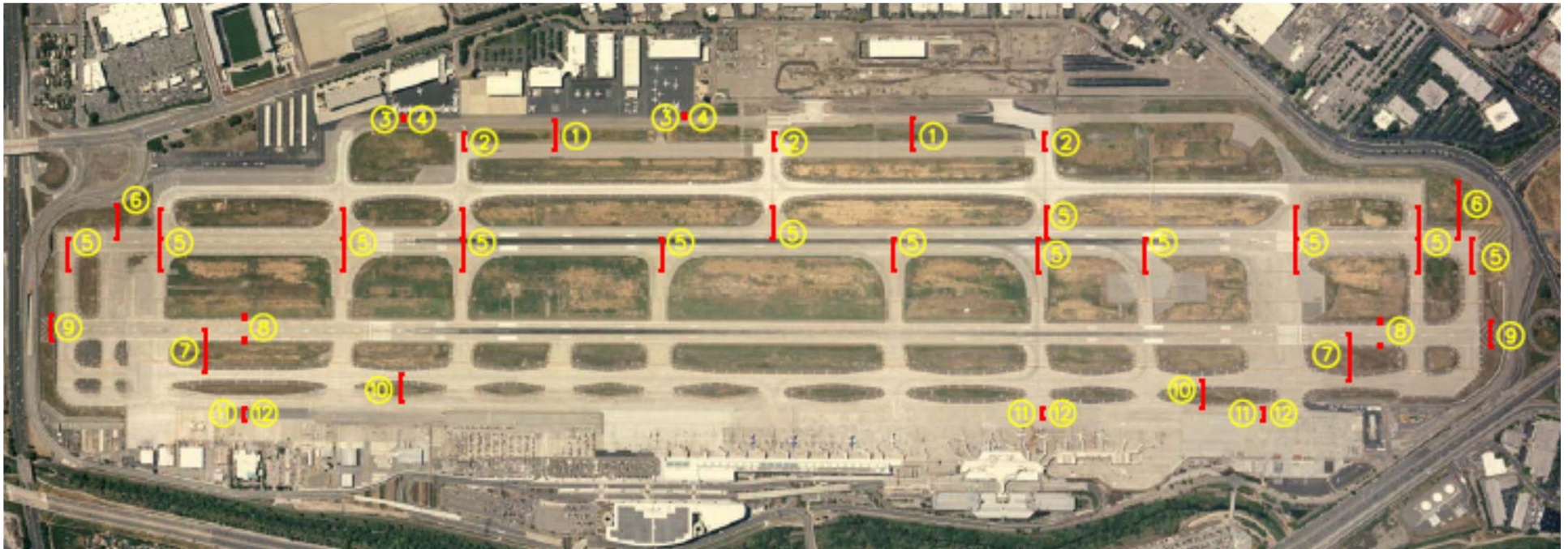

Security Technology Project



Estimate: \$14 million
Completion: April 2017

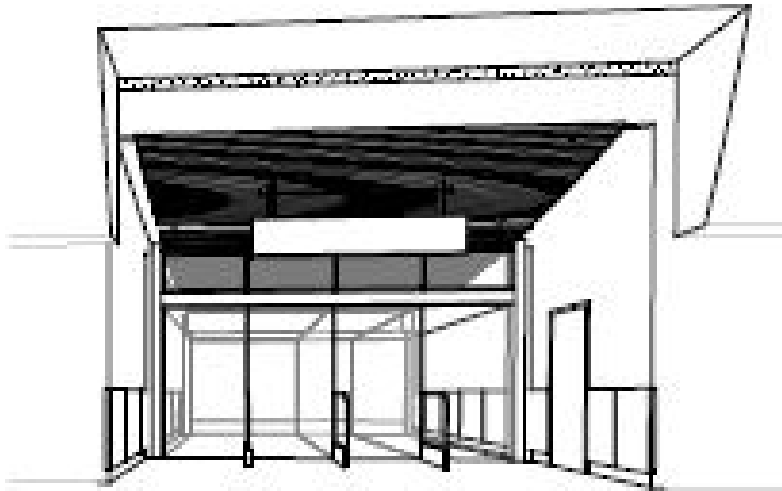

LAND SIDE VIEW

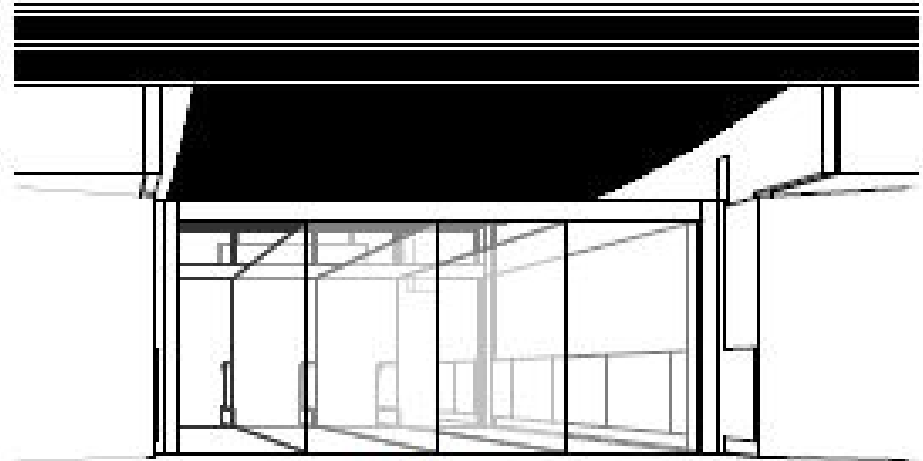

AIR SIDE VIEW



Terminal A Roadway Safety Improvements



Estimate: \$3.5 million
Completion: March 2017



Southeast Apron



Estimate: \$8.9 million
Completion: April 2017



Gate 29 and Gate 30



Estimate: \$10 million
Completion: June 2017



Airport Monument Sign



Estimate: \$750,000

Completion: February 2017





Questions
Thank You